



EMBRACE A SHARED FUTURE FOR
SMART ENERGY WITH **LISINER**



COMPANY PROFILE

LISINER specializes in advanced intelligent systems and energy storage technologies. We integrate cutting-edge manufacturing capabilities into national clean energy initiatives, striving to become a prominent sustainable enterprise. By incorporating big data, AI, IoT, and innovative ESS technologies into the green energy value chain, LISINER creates a smart solution that propels digital energy transformation. We are dedicated to pioneering and implementing innovative service models to cultivate a smart future for the entire energy ecosystem.

HONORS

- ✦ Year2024 Best Industrial & Commercial Energy Storage Solution Award
- ✦ Year2024 Best User-side Energy Storage Solution Award



MILESTONES



2017

The group established the Components Business Division.



2020

The Components Business Division achieved spin-off and was reorganized into the Yaoning Technology Group (YOE).



2021-2022

Subsidiaries like Yaoning New Energy, Tianci Mining, and Chengxing Chemical were established.



2022

LISINER was formally established as the fifth key business segment under YOE.



2023

LISINER is committed to driving industrial transformation and advancement as a company driven by talent and innovation.



2024

LISINER has landed 1GWh projects, which covered all major mainstream energy scenarios, and continues to explore the new development of technological innovation and industrial integration.



ENTERPRISE LAYOUT



HANGZHOU

Headquarters



HANGZHOU

Products R&D Center



HANGZHOU

Digital and AI Center



CHANGSHA

Technical Center



JIANGXI

Manufacturing Sites

CORE STRENGTHS



Manufacturing Strength

- ▶ Established two manufacturing sites in Yingtian and Shangrao, with a planned annual capacity exceeding 20GWh.



Mining and Materials Production

Energy Storage Products

Digital and AI Platform

Full Industry Participation

- ▶ Full industry participation across raw material mining, energy storage products, and digital & AI platforms.

BMS

Thermal Management

PCS

SesCloud

Self-research & Integration

- ▶ Achieve the strategy of [full-range of self-research], and reach the intelligence, standardization and modularization of products.

PRODUCTS AND SERVICES



Integrated Smart Energy Storage System

- ▶ Flexible Configuration
- ▶ Cost Reduction and Efficiency Improvement
- ▶ Safety and Reliability
- ▶ Intelligent Manufacturing Technology



Smart Energy Management System

- ▶ Remote Operation & Maintenance
- ▶ Integrated Management
- ▶ Intelligent Strategies
- ▶ Asset Value Enhancement



Comprehensive Energy Storage Solutions

- ▶ Peak Load Shaving
- ▶ Renewable Energy Consumption
- ▶ Dynamic Capacity Expansion
- ▶ Backup Power Supply



Smart Energy Services

- ▶ Comprehensive After-Sales Support
- ▶ Strict Delivery Process
- ▶ Omnichannel Customer Service
- ▶ Customized Services

CONTENTS

Built upon cutting-edge technology and propelled by innovation and R&D, LISINER delivers secure, efficient, and reliable energy storage systems, energy solutions, and a diverse range of services to a global clientele. LISINER aims to collaboratively develop a smart energy ecosystem with all partners to promote the sustainable development of the energy sector.

1

Smart Energy Storage Solutions and Products

- ▶ LV Distributed Energy Storage Solutions
- ▶ MV and HV Distributed Energy Storage Solutions
- ▶ Base Station Energy Storage Solutions
- ▶ Battery Pack

2

Smart Energy Management

- ▶ EMC5000 Centralized Control Cabinet
- ▶ EMC Master Control Box
- ▶ Energy Management Unit (EMU)

3

SesCloud Data & Intelligence Energy Platform

- ▶ Smart Energy Operations Control System
- ▶ SesAPM Asset Performance Management System
- ▶ SesEOM Energy Storage Operation System

SMART ENERGY STORAGE SYSTEM

LISINER leverages cutting-edge R&D expertise and manufacturing technology (PACK, BMS, EMS, PCS, etc.) to deliver intelligent solutions and energy management services known for their exceptional safety, cost-effectiveness, adaptability across various scenarios, holistic offerings, prolonged durability, and swift return on investment.



LV DISTRIBUTED ENERGY STORAGE SOLUTIONS

System Architecture

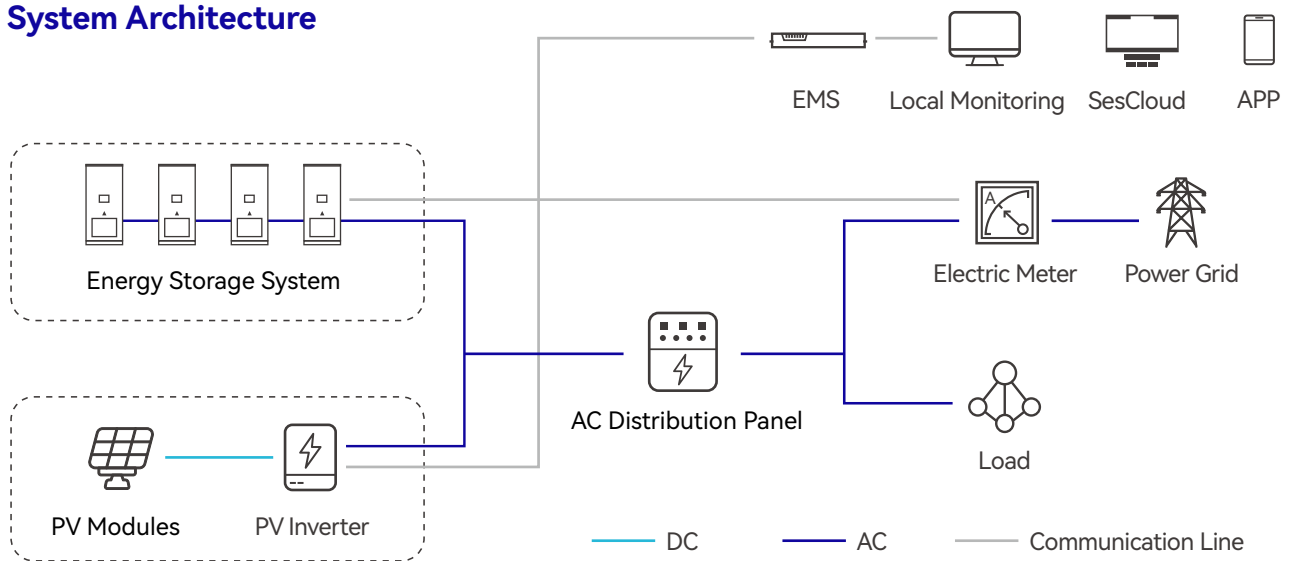

Communication Architecture

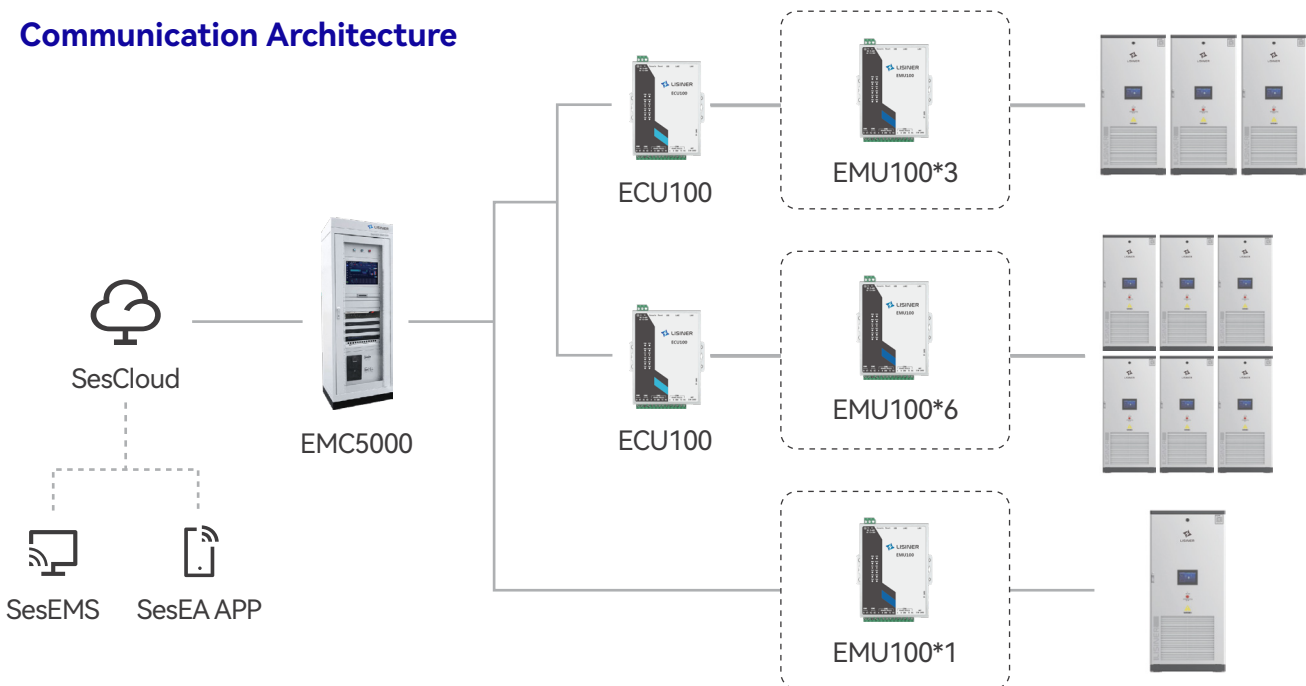

SOLUTION ADVANTAGES

All-in-one Design

All-in-one design for rapid deployment; easy connectivity, supporting multiple concurrent units, and offering straightforward scalability.

Safety and Reliability

Leveraging both gas and liquid fire suppression for precise fire extinguishment, with local and remote monitoring capabilities.

Quality and Efficiency Enhancement

Enabling a versatile wind-solar-battery-diesel hybrid, utilizing modular PCS, and allowing for independent battery cluster management to enhance system stability.

Intelligence

Leveraging advanced algorithms to optimize energy storage system's charging and discharging strategies, demand management, and dispatch responses, ultimately maximizing profitability.

APPLICATION SCENARIOS

- ▶ Industrial parks
- ▶ Commercial buildings (office buildings, shopping malls, hotels, hospitals, etc.)
- ▶ Intelligent solar-storage supercharging stations
- ▶ Data centers
- ▶ Transformer substation (TS) service area expansion

APPLICATION MODES

- ▶ Peak load shifting
- ▶ Dynamic capacity expansion
- ▶ Emergency backup provision
- ▶ Demand response aggregation



LV DISTRIBUTED ENERGY STORAGE PRODUCTS

KEY FEATURES



Ultimate Safety

- Incorporating a three-tier fire protection system at the cell, pack, and system levels to ensuring safety.
- Utilizing heat-resistant materials between cells to effectively mitigate thermal runaway risks.

High-Level Integration

- Featuring an “all-in-one” design, with a single cabinet occupying approximately 1.35m², reducing space requirements by 26% compared to conventional solutions.
- PCS is downward compatible with PDU, featuring integrated control, protection, and detection, enhancing unit installed capacity by 10%.
- Vertically integrating EMS with BMS, enabling unified aggregation and utilization of energy storage data, along with local intelligent strategy control.

High Energy Efficiency Management

- Utilizing advanced heat resistance and insulation technologies to maintain a temperature difference within 5°C at the product level, reducing energy consumption of liquid cooling units by 15%.
- Implementing graded heat control and intelligent heat management to sustain energy conversion efficiency above 88% throughout the year.
- Enabling PCS heat reuse to decrease auxiliary power consumption during winter.
- Ensuring a cell temperature difference below 2.8°C, a maximum temperature rise below 4.5°C, and a maximum cell temperature below 35°C, boosting cycle life by 20%.
- Employing AI algorithms for real-time operational strategy adjustments based on weather variations, enhancing system efficiency by approximately 1%.

High Reliability

- Automotive-grade pack production line that guarantees stringent quality control.
- Wide operating temperature range from -25°C to 55°C.
- Resistant to hurricanes of 15 mph and above.
- High corrosion resistance of above C4.

Cost Efficiency and Revenue Generation

- Incorporating a multi-fusion system design to decrease individual cabinet cost by 8% and shorten the ROI payback period.
- Utilizing lithium iron phosphate battery cells to boost installed energy per unit by 12%.

Intelligent Operations Control

- Enabling local energy management functions, such as dynamic demand tracking and control, peak load shifting, and time-of-use pricing.
- Facilitating various operational strategies for temperature regulation, fire protection, and PCS.
- Unified management of energy storage data for improved data management efficiency.
- Allowing for over-the-air (OTA) upgrades.

PRODUCT SPECIFICATIONS

Model	R232L1	R232L2	R261L1
BATTERY			
Nominal capacity	232.96kWh		261.24kWh
Usable capacity	221.31kWh		248.18kWh
Single Cell	3.2V 280Ah		3.2V 314Ah
Battery Pack	1P260S		
Battery technology	LFP		
Charge/discharge rate	≤0.5P (constant power)		
Cooling method	Liquid Cooling		
BMS (Battery Management System)	Integrated		
Rated DC voltage	832V		
DC voltage range	728Vdc ~ 936Vdc		
Battery life cycle	8000 CYC @25°C, 95% DOD, ≥70% EOL		
AC/DC INVERTER			
Operating voltage range (DC connection)	580V - 1000V		
Rated AC power	115kW	125kW	
Max AC power	125kW (Allow 30s)	150kW (Allow 30s)	
Rated AC current	166A	180A	
AC line voltage	400±15%		
Rated AC line frequency	50Hz/60Hz		
Rated AC line voltage	400V		
ENERGY MANAGEMENT SYSTEM			
EMS	Integrated		
COMMUNICATION			
Communication protocol	RS485/CAN/TCP		
Touch panel	10.1 " industrial standard		
Cloud	SUPPORT		
App	YES		
OPERATION			
Relative operating humidity	0 - 95%, no-condensation		
Operating temperature range	-25°C ~ 55°C		
Operating altitude	≤2000m		
System Efficiency	87%	89%	88%
Max. Efficiency	88%	90%	89%
DIMENSIONS (TOTAL)			
Dimensions (W x D x H)	1350x1310x2110mm	1007x1350x2250mm	
Weight	Aprox. 2600kg	Aprox. 2350kg	Aprox. 2380kg
SAFETY/STANDARDS			
Protection	IP54		
Safety features	a. Smoke detection b. Temperature detection c. Aerosol fire extinguish d. Siren and strobe alarm e. Emergency stop button		
Certification	IEC 62619, EN61000-6-1/-2/-3/-4, IEC 60730-1, IEC 62477-1, UN38.3, UN3480, EN50549-1, EN50549-10, VDE-AR-N-4105, VDE-AR-N-4110, VDE-AR-N-4120, G99, UNE217001, UNE217002, NTS631, TOR Erzeuger, NRS097-2-1, AS 4777.2, CEI-016, CEI-021.		GB/T36276-2023
WARRANTY			
Warranty	5 years (Option: 10 years)		

MV & HV ENERGY STORAGE SOLUTION

SOLUTION ADVANTAGES

Generation-Side Applications

- ▶ Reducing wind and solar energy curtailments, delivering economic benefits.
- ▶ Monitoring projected output to fortify the stability of renewable energy generation systems.
- ▶ Enhancing power reliability, and facilitating renewable energy grid integration.
- ▶ Mitigating grid impacts and fluctuations.

Grid-Side Applications

- ▶ Delaying the need for investment in expanding transmission and distribution capacity, and easing line congestion.
- ▶ Engagement in peak shaving, frequency regulation, AGC, AVC, and other ancillary power services.
- ▶ Facilitating the consumption of renewable energy, and bolstering grid stability.
- ▶ Swift dynamic response and precise power regulation.

User-Side Applications

- ▶ Modular and standardized design for simplified installation and setup.
- ▶ Utilizing self-developed BMS, PCS and EMS, enabling autonomous operation of energy storage stations.
- ▶ Eliminating on-site commissioning requirements, ensuring easy installation.

APPLICATION MODES

- ▶ Peak Shaving and Frequency Regulation
- ▶ Power Quality Management
- ▶ Renewable Energy Consumption
- ▶ Peak Load Shifting

APPLICATION SCENARIOS

- ▶ Generators
- ▶ Grid
- ▶ Industrial Parks
- ▶ Commercial Buildings
(Office buildings, shopping malls, hotels, hospitals, etc.)
- ▶ Intelligent Solar-Storage Supercharging Stations
- ▶ Data Centers
- ▶ Transformer substation (TS) service area expansion

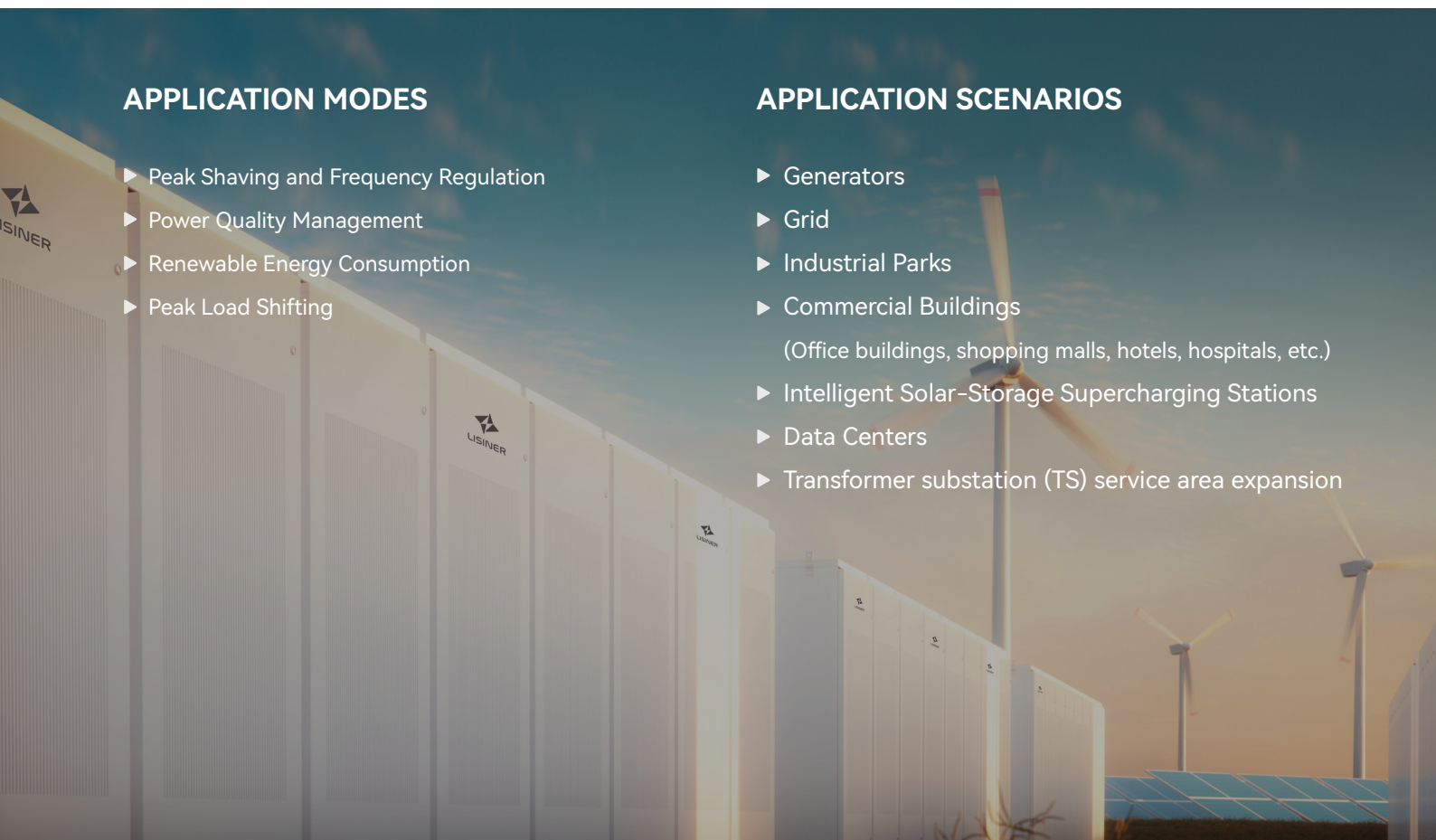

System Architecture

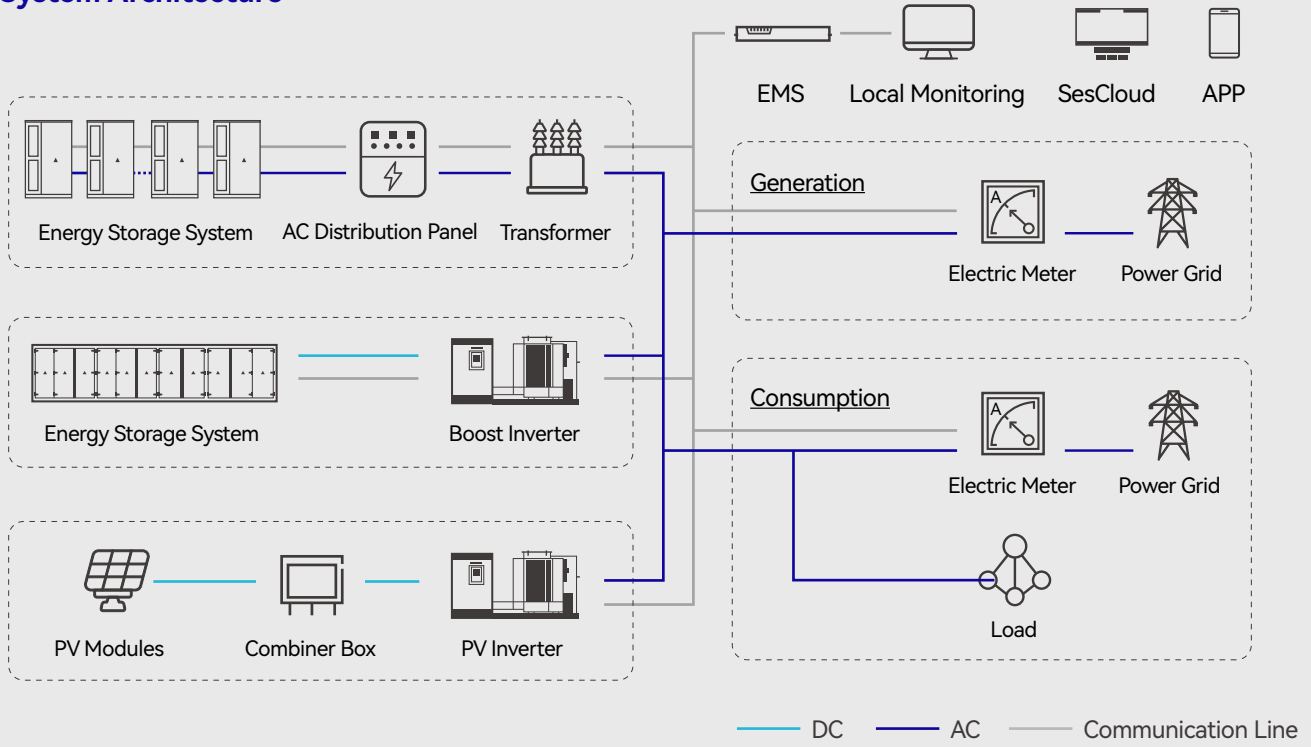

Communication Architecture

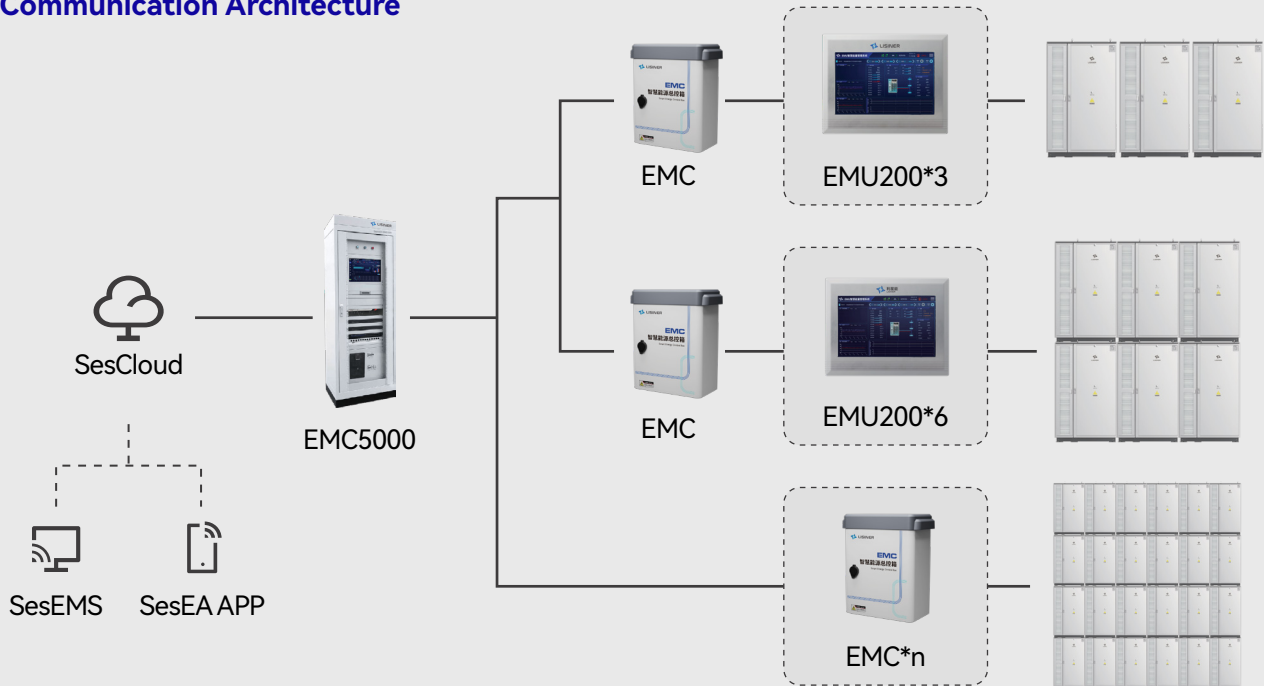

MV & HV DISTRIBUTED ENERGY STORAGE PRODUCTS

KEY FEATURES



Advanced Safety Design

- **3+2 Safety System:** Three-tier fire protection design + dual safety assurance.
- **AI-Based Early Warning:** Utilizing automotive-grade battery cells for AI-enabled battery fault warning.

Streamlined and Flexible

- **Efficient Layout:** Vertical alignment of AC and DC components, reducing the footprint of PCS and water cooling units, decreasing individual product volume by 25%.
- **Dynamic Capacity Expansion:** Supporting side-by-side and back-to-back mounting to maximize space utilization, ensuring flexibility and scalability without limitations on site layout.

Lower LCOS

- **Ultra-long Life:** Enhancing battery pack consistency to extend system life by 20%.
- **Efficient Heat Dissipation:** Utilizing liquid-cooled pack, maintaining a cell temperature difference less than 2.8°C, and reducing auxiliary energy consumption by 30%.
- **Separate Management of Each Cluster:** The inter-cluster voltage balancing control eliminates the barrel effect, yielding an 8% increase in capacity over the battery lifecycle.

Convenient and Reliable

- **Easy Grid Connection:** Comprehensive performance and functional testing conducted prior to shipment, eliminating the need for on-site commissioning, enabling immediate grid connection upon arrival.
- **Minimal Dismantling Requirement:** Assigning one PCS per cluster achieves 90% reduction in fault losses compared to conventional solutions.
- **Robustness in Challenging Environments:** Ability to withstand diverse outdoor conditions, including high temperatures, extreme cold, high humidity, and high altitudes.

Intelligent Management

- **Remote Management:** Online intelligent monitoring for decreased manual inspection frequency.
- **Dynamic Adjustment:** High SOC accuracy enables dynamically adapting energy management strategies based on load requirements.
- **Versatile Operation:** Built-in peak load shifting, demand response, backup power, and command response functionalities.

PRODUCT SPECIFICATIONS

Model	R372L2	R418L1
BATTERY		
Nominal capacity	372.73kWh	418kWh
Usable capacity	354kWh	397kWh
Single Cell	3.2V 280Ah	3.2V 314Ah
Battery Pack	1P416S	
Battery technology	LFP	
Charge/discharge rate	≤0.5P (constant power)	
Cooling method	Liquid Cooling	
BMS (Battery Management System)	Integrated	
Rated DC voltage	1331.2V	
DC voltage range	1164.8Vdc ~ 1497.6Vdc	
Battery life cycle	8000 CYC @25°C, 95% DOD, ≥70% EOL	
AC/DC INVERTER		
Operating voltage range (DC connection)	1000V - 1500V	
Rated AC power	186kW	209kW
Max AC power	258kW (Allow 30s)	
Rated AC current	156A	175A
AC line voltage	690V(-20%~+15%)	
Rated AC line frequency	50Hz	
Rated AC line voltage	690V	
ENERGY MANAGMENT SYSTEM		
EMS	Integrated	
COMMUNICATION		
Communication protocol	RS485/CAN/TCP	
Touch panel	10.1 " industrial standard	
Cloud	SUPPORT	
App	YES	
OPERATION		
Relative operating humidity	0 - 95%, no-condensation	
Operating temperature range	-25°C ~ 55°C	
Operating altitude	≤2000m	
System Efficiency	88.5%	89%
Max. Efficiency	89.5%	90%
DIMENSIONS (TOTAL)		
Dimensions (W x D x H)	1402x1338x2320mm	
Weight	Aprox. 3400kg	Aprox. 3500kg
SAFETY/STANDARDS		
Protection	IP54	
Safety features	a. Smoke detection b. Temperature detection c. Aerosol fire extinguish d. Siren and strobe alarm e. Emergency stop button	
Certification	GB/T36276-2023	
WARRANTY		
Warranty	5 years (Option: 10 years)	

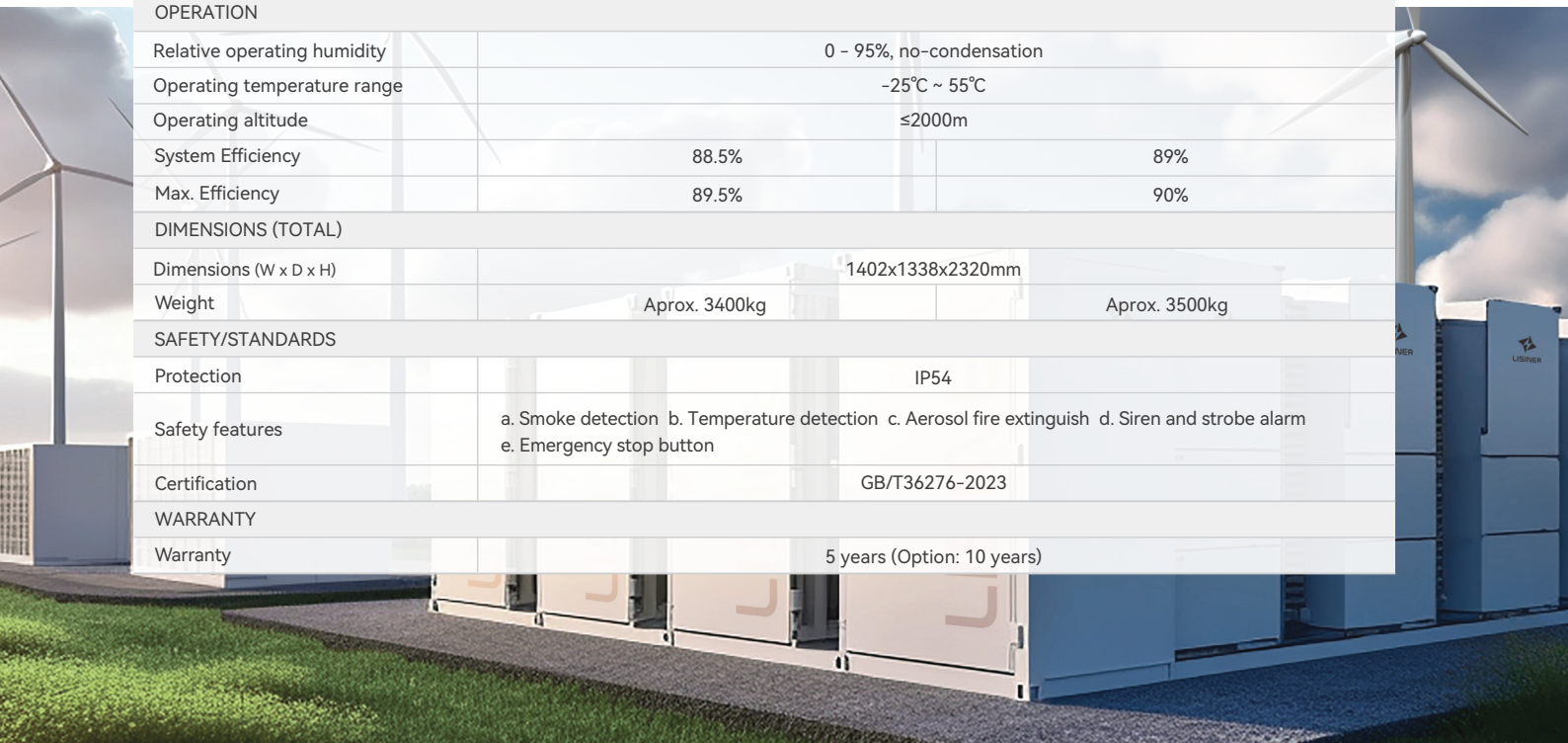

MV & HV CONTAINERIZED ENERGY STORAGE PRODUCTS

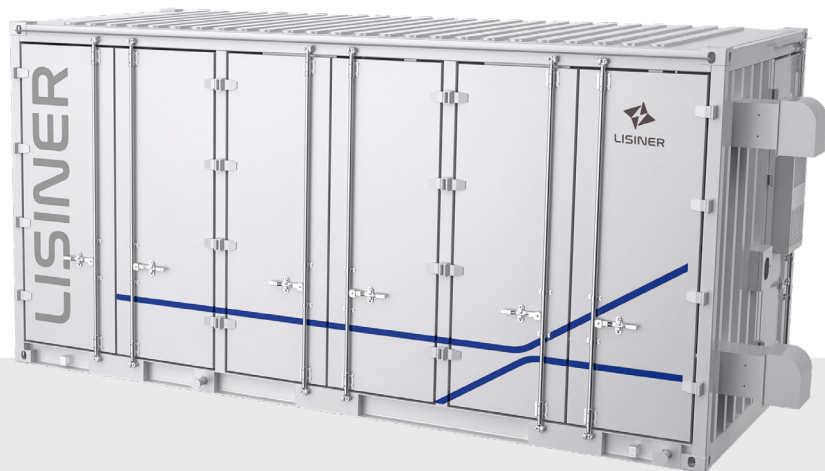

KEY FEATURES

Integrated BMS & EMS Control



Enhanced discharge capacity through intelligent and flexible control through BMS and EMS coordination.

Cost Efficiency and Performance Enhancement



High integration leading to a 30% boost in energy density and a 20% decrease in system losses.

Lifecycle Management



Comprehensive lifecycle management incorporating liquid cooling technology, intelligent battery health management, and more.

Effective Thermal Management



Precise temperature control: system temperature maintained below 35°C, inter-cluster temperature difference kept within 3°C, and system-level temperature difference within 5°C.

PRODUCT SPECIFICATIONS

Model	C2508L1	C3344L1	C4180L1	C5016L1
BATTERY				
Nominal capacity	2.508MWh	3.344MWh	4.180MWh	5.016MWh
Usable capacity	2.382MWh	3.176MWh	3.971MWh	4.765MWh
Single cell	C314			
Battery pack	416S1P*6	416S1P*8	416S1P*10	416S1P*12
Battery technology	LFP			
Charge/discharge rate	≤0.5P (constant power)			
Cooling method	Liquid Cooling			
BMS (Battery Management System)	Integrated			
Rated DC voltage	1331.2V			
DC voltage range	1164.8Vdc ~ 1497.6Vdc			
Battery life cycle	8000 CYC @25°C, 95% DOD, ≥70% EOL			
COMMUNICATION				
Communication protocol	RS485/CAN/TCP			
Touch panel	10.1 " industrial standard			
OPERATION				
Relative operating humidity	0 - 95%, no-condensation			
Operating temperature range	-25°C ~ 55°C			
Operating altitude	≤5000m			
DIMENSIONS (TOTAL)				
Dimensions (W x D x H)	6058x2438x2896mm			
Weight	Aprox.27t	Aprox. 32t	Aprox. 37t	Aprox. 42t
SAFETY/STANDARDS				
Protection	IP55			
Safety features	a. Flammable/explosive gas detection b. Flammable/explosive gas exhaust c. Smoke detection d. Temperature detection e. Aerosol fire extinguish f. Siren and strobe alarm g. Emergency stop button			
Certification	IEC 62619, IEC 63056, IEC 61000-6-2/-4, IEC 60730-1, IEC 62477-1, IEC 62933-5-2, UN38.3, UN3536			
WARRANTY				
Warranty	5 years (Option: 10 years)			

BASE STATION ENERGY STORAGE SOLUTION

System Architecture

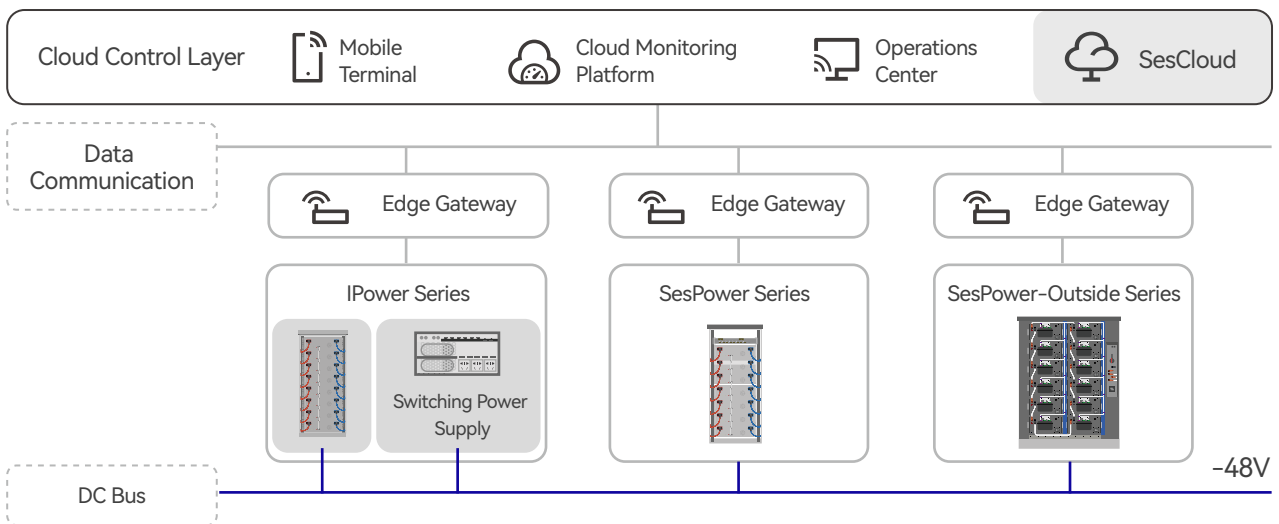

Hybrid Lead-acid/Lithium-ion Battery Architecture

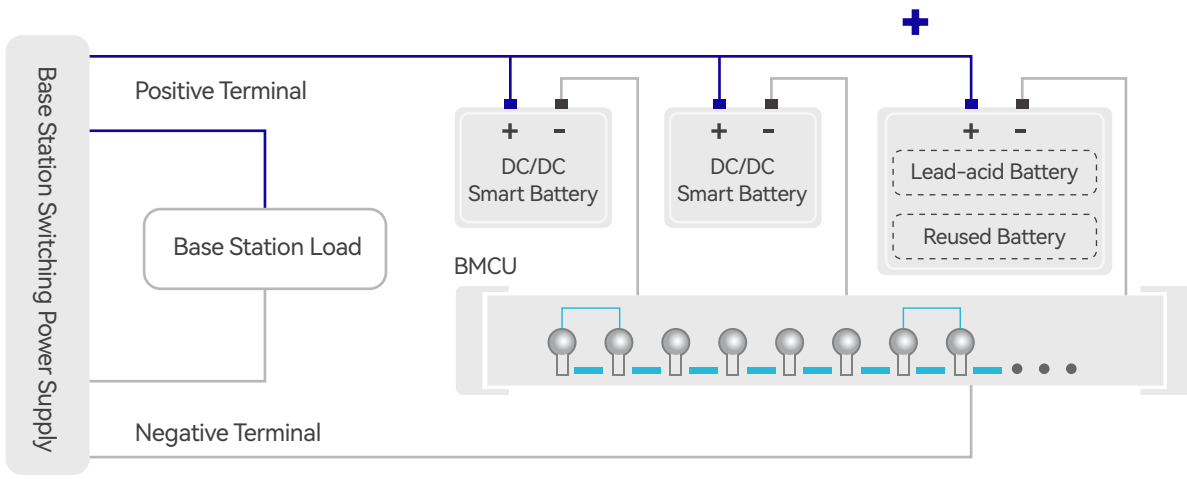

SOLUTION ADVANTAGES

Minimal Conversion Losses

Utilizing bidirectional high-efficiency DC-DC circuit design, achieving unidirectional conversion efficiency of up to 99%.

Cost-Effective Operations

Energy storage assets engage in peak load shifting, reducing overall electricity costs for customers.

Extended Life

High-spec models engineered for a 15-year life.

Smart Energy Management

Utilizing AI-enabled energy management for adaptive power generation, boosting battery cycle life by 20%.

Enhanced Safety

Incorporating a double-layer flame-retardant explosion-proof design.

Modular Design

Adaptable to various power supply solutions for base stations.

APPLICATION SCENARIOS

- ▶ Energy storage for 4/5G base stations
- ▶ Power supply solutions for wind-solar-battery demands at base stations

OTHER SCENARIOS

- ▶ Energy storage for small to medium-sized data centers
- ▶ Replacement for UPS systems
- ▶ Park microgrid
- ▶ Island microgrid



IPOWER SERIES



KEY FEATURES

High Integration Design



Integration of switch power supply, IoT gateway, and battery into an all-in-one design.

Convenient O&M



Modular design for easy transportation, installation, and maintenance with plug-and-play functionality.

Improved Cost-Effectiveness



Precise electricity deployment leading to a 10% increase in return on investment over the lifecycle.

Multi-Energy Integration



Supporting the integration of solar and wind power, meeting the requirements for transitioning to green base stations.

Compact Design



High energy density within a single cabinet, minimizing space requirements.

PRODUCT SPECIFICATIONS

Model	G48100P30	G48150P30
Battery Pack	G48100	G48150
Grouping Mode	16S1P*6	16S1P*4
Nominal Voltage	51.2V	51.2V
Operating Voltage	44~58V	44~58V
Nominal Energy	5.12*6 kWh	7.68*4 kWh
Rated Charge/Discharge Rate	0.5C	0.5C
Max. Charge/Discharge Rate	1C	0.65C
Charge/Discharge Energy Efficiency	≥92%	≥92%
Protection Grade	IP43	IP43
Thermal Management Technology	Smart air cooling	Smart air cooling
Charging Temperature	0-55°C	0-55°C
Discharging Temperature	-20-55°C	-20-55°C
Cycle Life	≥6000	≥6000
Dimensions (W*D*H)	600×600×2000mm	600×600×1700mm



SESPower SERIES



KEY FEATURES

High Conversion Efficiency



DC-side connection ensures an overall energy conversion efficiency of over 94% under standard conditions.

Enhanced Utilization



Every battery cell features independent charge and discharge control, boosting system throughput by 15% and enhancing battery capacity utilization by 50%.

Battery Compatibility



Allowing for the mixing of new and old batteries, as well as lead-acid and lithium-ion batteries, and different battery models.

Intelligent O&M



Intelligently diagnosing system operating status to enhance fault handling efficiency and reduce manual operation and maintenance costs.

Smart Strategies



Intelligent deployment of operational strategies, managing battery charge/discharge data to enable varied charging and discharging patterns for batteries.

PRODUCT SPECIFICATIONS

Model	P48100P30	P48150P30
Battery Pack	P48100	P48150
Grouping Mode	16S1P*6	16S1P*4
Nominal Voltage	51.2V	51.2V
Operating Voltage	44~58V	44~58V
Nominal Energy	5.12*6 kWh	7.68*4 kWh
Rated Charge/Discharge Rate	0.5C	0.5C
Max. Charge/Discharge Rate	1C	0.65C
Charge/Discharge Energy Efficiency	≥94%	≥94%
Protection Grade	IP43	IP43
Thermal Management Technology	Smart air cooling	Smart air cooling
Charging Temperature	0-55°C	0-55°C
Discharging Temperature	-20-55°C	-20-55°C
Cycle Life	≥6000	≥6000
Dimensions (W*D*H)	600×600×1500mm	600×600×1200mm

SEMOS BMCU100

BMCU (Battery Main Control Unit) serves as the central control and management hub for the base station energy storage system. It interfaces with all battery pack within the system, collaborates with the cloud platform to enable adaptive electricity pricing, and optimizes operational strategies. Additionally, it facilitates communication with the switch power supply, monitors charge and discharge processes, and interfaces with the power grid dispatching system or operational platform.



- ▶ Supporting protocols such as SAEJ1939, Modbus, YDT1363, and DL645
- ▶ Edge computing capability, enabling logical programming through scripting languages
- ▶ Networked configuration and maintenance, facilitating OTA upgrades for BMS

SESPOWER OUTSIDE SERIES



KEY FEATURES

Versatile AC/DC Configuration



Featuring a modular design, it accommodates AC, DC, and AC/DC coupling solutions to cater to a wide range of requirements.

Diverse Applications



Ideal for communication base stations, with potential reuse in residential energy storage, commercial areas, TS service areas, and mobile device charging.

Enhanced Safety



Utilizing a multi-tier fire protection design, which incorporates cell-level AI-enabled automated monitoring, pack-level passive heat diffusion prevention, and system-level electrical safety cutoff mechanisms.

Swift Responsiveness



Boasting a dispatch response time of less than 20ms, ensuring smooth power supply transitions for communication base stations, and facilitating seamless switching between on-grid and off-grid modes.

Intelligent Operational Control



Automatically devising operational control strategies to enhance power supply service and minimize electricity costs.

PRODUCT SPECIFICATIONS

Model	P48030	P48061	P48030
Battery Pack	P48100	P48100	P48150
Grouping Mode	16S1P*6	16S1P*12	16S1P*4
Nominal Voltage	51.2V	51.2V	51.2V
Operating Voltage	44~58V	44~58V	44~58V
Nominal Energy	30kWh	61kWh	30kWh
Rated Charge/Discharge Rate	0.5C	0.5C	0.5C
Max. Charge/Discharge Rate	1C	1C	1C
Charge/Discharge Energy Efficiency	≥92%	≥92%	≥92%
Protection Grade	IP54	IP54	IP54
Thermal Management Technology	Smart air/liquid cooling	Smart air/liquid cooling	Smart air/liquid cooling
Charging Temperature	0-55°C	0-55°C	0-55°C
Discharging Temperature	-20-55°C	-20-55°C	-20-55°C
Cycle Life	≥6000	≥6000	≥6000
Dimensions (W*D*H)	900×900×1800mm	1800×900×1800mm	900×900×1200mm



1P52S LIQUID-COOLED BATTERY PACK

Featuring lithium-iron phosphate batteries and a liquid cooling temperature control system to minimize cell temperature variations and enhance the safety of the energy storage system. Designed to support pack-level fire protection and immersion cooling, with customization options available to optimize battery safety according to customer preferences.



PRODUCT SPECIFICATIONS

Model	1P52S-280Ah	1P52S-314Ah	1P52S-306Ah	1P64S-280Ah	1P64S-314Ah	1P64S-306Ah
Grouping Mode	1P52S	1P52S	1P52S	1P64S	1P64S	1P64S
Nominal Voltage	166.4V	166.4V	166.4V	204.8V	204.8V	204.8V
Rated Capacity	280Ah	314Ah	306Ah	280Ah	314Ah	306Ah
Rated Energy	46.6kWh	52.2kWh	50.9kWh	57.3kWh	64.3kWh	62.7kWh
Rated C-Rate	0.5P	0.5P	0.5P	0.5P	0.5P	0.5P
Weight	330kg	345kg	345kg	400kg	420kg	420kg
Dimensions (L×D×H)	810×1100×240mm	810×1100×240mm	810×1100×240mm	810×1300×240mm	810×1300×240mm	810×1300×240mm
Thermal Management Technology	Liquid cooling/heating	Liquid cooling/heating	Liquid cooling/heating	Liquid cooling/heating	Liquid cooling/heating	Liquid cooling/heating

KEY FEATURES

Efficient Thermal Control



Ensuring a maximum temperature difference of $\leq 3^{\circ}\text{C}$ between batteries and a maximum temperature rise of $\leq 5^{\circ}\text{C}$.

Extended Life



Delivering a 15% increase in cycle life compared to air-cooled systems.

Enhanced Energy Density



Achieving a 10% boost in energy density per pack compared to air-cooled systems.

Robust Safety



Implementing pack-level fire protection to ensure comprehensive safety.

IBP48100 SMART LITHIUM-ION BATTERY PACK

A standardized battery module tailored to fulfill the power requirements of communication base stations. Featuring intelligent active voltage regulation, cell health monitoring capabilities for distributed management and control. Integrated with cloud platforms to offer intelligent operations, remote maintenance, and one-click management features.



PRODUCT SPECIFICATIONS

Model	IBP48100	IBP48150
Grouping Mode	1P16S	1P16S
Nominal Voltage	51.2V	51.2V
Rated Capacity	100Ah	150Ah
Rated Energy	5.12kWh	7.68kWh
C-rate	1C	0.5C
Communication Interface	RS485/CAN	RS485/CAN
Weight	44kg	60kg
Dimensions (L×D×H)	442×480×134mm	442×480×134mm
Certification	CE UN38.3	CE UN38.3

KEY FEATURES



Intelligent hybrid system integrating lithium-ion and lead-acid batteries to cater to varied requirements.



Implementing proactive balancing strategies to enhance cycle life.



Networked setup and maintenance and OTA upgrades of BMS enable convenient remote O&M.



Incorporating safety features like over-temperature, over-current, short circuit, overcharge, and over-discharge protection.

END-EDGE-CLOUD-NETWORK COLLABORATIVE SMART ENERGY MANAGEMENT

Leveraging IoT, edge computing, cloud computing, cloud storage, artificial intelligence, and other cutting-edge technologies, LISINER is dedicated to developing tailored digital solutions for diverse scenarios, offering user-friendly applications, remote monitoring, and intelligent O&M for a sustainable, net-zero future powered by digital innovation.

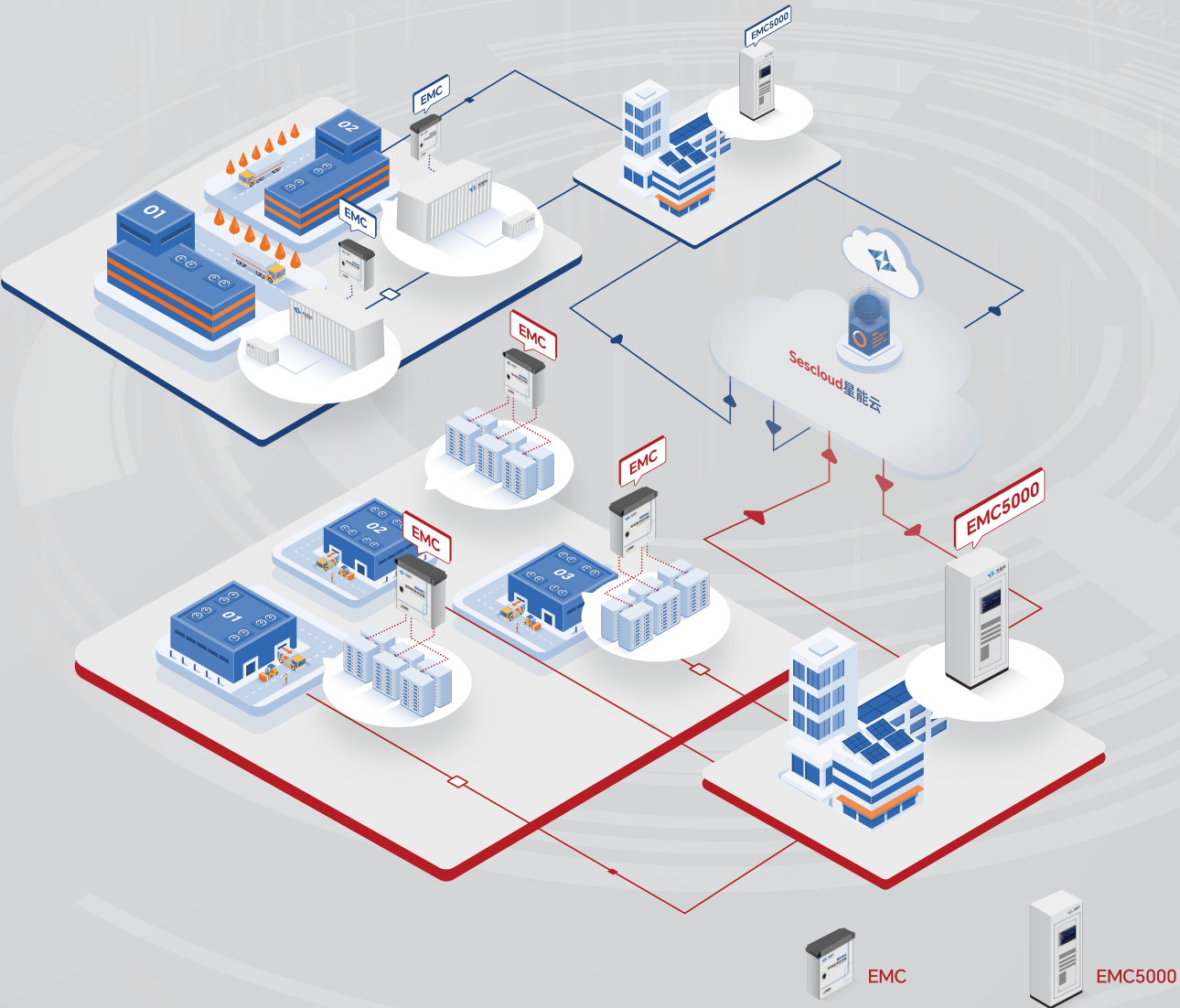

EMC5000 CENTRALIZED CONTROL CABINET

Designed for large-scale energy storage facilities, this locally expandable EMS control solution combines hardware and software for swift on-site deployment and seamless operation.

- ▶ Facilitating the connection and management of the primary control unit across numerous distributed grid entry points or container systems, promptly addressing grid dispatch instructions;
- ▶ Continuously optimizing operational strategies in real time by leveraging time-of-use electricity pricing, ensuring centralized regional energy control to enhance the overall efficiency of the energy storage system.



KEY FEATURES

Real-time Responsiveness



Enabling domain energy dispatching control in milliseconds.

Security Assurance



Incorporates industrial-grade data security modules to meet stringent security requirements.

High Connectivity



Including a diverse communication protocol library, ensuring strong data connectivity capabilities.

PRODUCT SPECIFICATIONS

System Setup		Communication Parameters	
Centralized Control System	EMC5000	Communication Interface	Ethernet, Fiber Optic, 4G, RS485, CAN, IO
Energy Management Unit	EMU100	Communication Protocol	Modbus, IEC101, IEC104, MQTT, etc.
Cloud Gateway	CGW100	General Parameters	
GPS	GPS/Beidou	Voltage	200 ~ 240VAC
Synchronized Clock System	ISC100	Power Consumption	<2000W
UPS	3kVA/60min	Dimensions (W*H*D)	600×2260×800mm

SYSTEM FEATURES



Panoramic Monitoring



Strategy Optimization



Alerts Display



Real-time Supervision



Comprehensive Controlling

SMART ENERGY CONTROL HUB



As the core of EMC5000, the control hub boasts capabilities including data collection, real-time data processing and analysis, and dynamic data visualization, empowering energy control and dispatching management.

- ▶ Designed for cross-platform compatibility, seamlessly supporting Linux and Windows operating systems.
- ▶ A single hub can handle up to 50,000 points of real-time data.
- ▶ Compact 2U rack-mounted design with a fully enclosed fanless structure.

EMC MASTER CONTROL BOX

This highly integrated standardized local EMS master control solution combines hardware and software for coordinated control and on-site monitoring of individual grid entry point (including multiple energy storage cabinets) or containerized BESS.

- ▶ Seamless interface with the EMC5000 control system, enabling plug-and-play functionality for rapid deployment.
- ▶ By incorporating the EMU100 module, the capacity for connected energy storage cabinets can be expanded at any time.



KEY FEATURES

Versatile Compatibility



Multiple built-in interface protocols ensure compatibility with energy storage products from various manufacturers.

Robust Performance



Featuring a WDT design for system stability assurance. Capable of handling centralized processing and redistribution of extensive data. Employing powerful edge computing capabilities, supporting scripting languages and logical programming. Fully networked configuration and maintenance, with online message analysis capabilities.

User-Friendly Operation



Modular and standardized products with plug-and-play functionality.

PRODUCT SPECIFICATIONS

Communication Parameters	
Communication Interface	Ethernet, RS485, CAN, IO
Communication Protocol	Modbus, DL645, IEC101, IEC104, MQTT, etc.
System Setup	
Coordinated Controller	ECU100
Industrial Switch	8 Port
General Parameters	
Voltage	200 ~ 260VAC
Power Consumption	<100W
Dimensions (W*H*D)	400×500×200mm



ECU100 COORDINATED CONTROLLER



The ECU100, a coordinated controller, is designed for distributed energy storage systems. It gathers data from energy storage units, anti-backflow meters, and grid-connected meters, to coordinate and control the charge and discharge operations of multiple energy storage units at grid entry points. This enables functions such as peak load shifting, anti-backflow prevention, overload protection, and demand management.

- ▶ Equipped with an industrial-grade A9 processor with a high frequency of up to 1.4GHz.
- ▶ Offering comprehensive support for industrial communication protocols.
- ▶ Possessing edge computing capabilities and supporting scripting languages and logical programming.

INTELLIGENT ENERGY MANAGEMENT UNIT

EMU200



EMU200 serves as a comprehensive edge control terminal tailored for distributed energy storage systems. It facilitates data tracking across all stages, encompassing production configuration, testing, installation debugging, operation monitoring, and equipment maintenance. The unit enables intelligent management throughout the product lifecycle.

KEY FEATURES

- ▶ An industrial-grade quad-core 64-bit high-performance processor, up to 2GHz
- ▶ A highly integrated hardware design that supports various interfaces and features a 10-inch touchscreen display
- ▶ Cloud-edge collaboration with unified access control
- ▶ Simplified one-click control for charging and discharging strategies with real-time synchronization
- ▶ Intelligent lifecycle management for energy storage units
- ▶ Complete integration of all EMU100 functions

EMU100



EMU100 is a station-side edge device designed for distributed energy storage systems. It supports a variety of interfaces and communication protocols for tasks such as data collection, strategy control, data transmission, and other essential functions.

KEY FEATURES

- ▶ Industrial-grade A9 processor, up to 1.4GHz
- ▶ Extensive support for industrial communication protocols
- ▶ Capable of one-way data acquisition
- ▶ Centralized data processing and redistribution capabilities
- ▶ Edge computing support with script language and logical programming features
- ▶ Connectivity to various cloud platforms

PRODUCT SPECIFICATIONS

Model		EMU200	EMU100
Hardware	CPU	Industrial-grade quad-core 64-bit Cortex-A55, 2.0GHz	Industrial-grade quad-core A9 processor, 1.4GHz
	Memory	2GB	512MB
	Storage	8GB, supports SSD expansion	8GB
	Display	10.1-inch LCD screen	Optional
	Resolution	1280*800	Optional
	Touchscreen	4-wire industrial resistive touchscreen	Optional
	4G	4G LTE	4G LTE
	GNSS	Beidou, GPS	/
	Input	DC12V/24V	DC9V ~ 48V
Interface	Ethernet	2 ports	2 ports
	Serial Ports	6 RS485 ports, 1 multiplexed RS232 port	4 RS485 ports, 2 multiplexed RS232 ports
	CAN	2 ports	Optional
	DI	6 ports	Optional
	DO	6 ports	Optional
Physical Property	Dimensions (W*H*D)	281×223×49mm	117×129×28mm
	Weight	1.5kg	0.5kg
	Installation Method	Embedded, bracket mounting	Wall mounting, rail mounting
System	Operating System	Linux	
	Communication Protocols	ModbusRTU/ASCII/TCP, IEC101, IEC103, IEC104, YD/T1363, DL/645-1997/2007, DNP, SNMP, Modbus one-way data acquisition, DL/T645 one-way data acquisition, general custom configuration protocols, etc.	
	Cloud Protocols	MQTT、HTTP	

SYSTEM FEATURES



Panoramic Monitoring



Grid Entry Point Monitoring



Data Analysis



Alarm Management



Cloud-Edge Collaboration



Information Configuration

SESCLOUD DIGITAL & AI ENERGY PLATFORM

SesCloud Smart Energy Platform is an intelligent infrastructure designed for the development and operation of smart application systems tailored to energy storage, consumption and trading scenarios. At its core, SesCloud incorporates industrial big data management and AI intelligent analysis, all built on cloud-native technology. Serving as a versatile platform, SesCloud enables the swift development and seamless integration of intelligent energy applications like SesEMS and EnergyOn. It offers extensive access to heterogeneous IoT networks, robust industrial big data storage and management, unified data service interfaces, advanced AI computing architecture, top-notch information security, and a range of other essential infrastructure components.



SESEMS INDUSTRIAL AND COMMERCIAL ENERGY MANAGEMENT SYSTEM



SesEMS enables the smooth integration of various systems and devices spanning wind, solar, energy storage, and charging. Users benefit from real-time monitoring, intelligent analysis, and optimized dispatching functionalities. The system supports multiple operational and profit models, including peak-valley arbitrage, demand management, and the wind-solar-storage-charging integration. Through these capabilities, industrial and commercial entities can efficiently manage electricity costs, increase the value of energy storage assets, and pursue new opportunities for business expansion.



KEY FEATURES

Panoramic Monitoring



Offering in-depth, multi-tier monitoring of energy storage systems, enabling real-time critical data collection and monitoring for each battery cell. It provides real-time assessment of the operating status of cells, modules, pack and energy storage cabinets, ensuring system transparency and visualization.

Cloud-End Collaboration



Facilitating cloud-end collaborations with intelligent energy management units for effortless self-registration and integrated intelligent configuration, resulting in a significant reduction in on-site configuration efforts.

Wide Adaptability



Adapting to energy storage systems of different capacities, supporting a range of application scenarios including energy storage, integrated wind-solar-storage-charging systems, and various operational strategies such as peak-valley arbitrage.

Intelligent Driven Solution



Incorporating AI and big data analysis to autonomously generate diverse optimization strategies like energy storage peak-valley arbitrage and wind-solar-storage-charging integration. It conducts thorough analysis and intelligent diagnostics of energy storage system operations and economic benefits.

CORE FUNCTIONS



Panoramic Monitoring



Intelligent Strategy Formulation

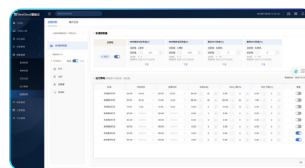

Advanced Analysis



Smart Reporting

ENERGYON ICT ENERGY MANAGEMENT SYSTEM

EnergyOn is tailored for energy storage applications in communication base stations, offering extensive monitoring of energy storage system and power and environment supervision system. It facilitates the seamless integration of renewable energy sources like wind and solar power. Through the generation of intelligent strategies informed by load profiles and electricity pricing, it empowers the development of holistic green energy self-use and peak-valley arbitrage strategies. The system is geared towards improving the reliability of power supply services, cutting base station electricity costs, facilitating dispatch responsiveness, enabling multi-site aggregation, and establishing virtual power plants for demand response.



KEY FEATURES

Panoramic Monitoring



Conducting extensive monitoring of communication base stations across various locations, encompassing real-time tracking of system operational efficiency, status of power and environment supervision system, load profiles, energy storage systems, and the operating status of renewable energy sources such as wind and solar power.

Smart Maintenance



Utilizing intelligent diagnostics to assess the status of energy storage systems and batteries, pinpointing anomalies and faults. Remote upgrades are executed through OTA updates to minimize the need for on-site visits.

Intelligent Operational Control



Automatically formulating optimal operational control strategies by considering load demands, backup power necessities, and the integration of wind and solar power, thereby achieving the goals of enhancing power supply service and cutting electricity costs.

Aggregation Dispatching



Responding intelligently to higher-level dispatching based on load forecasts for individual stations; aggregating energy storage systems from numerous base stations to engage in demand response and other higher-level dispatching modes.

CORE FUNCTIONS

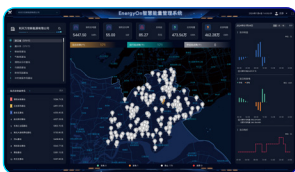

Panoramic Monitoring

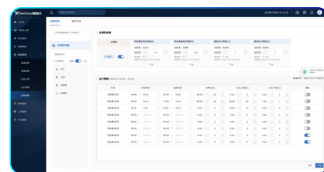

Intelligent Operations
Control



Aggregation Dispatching

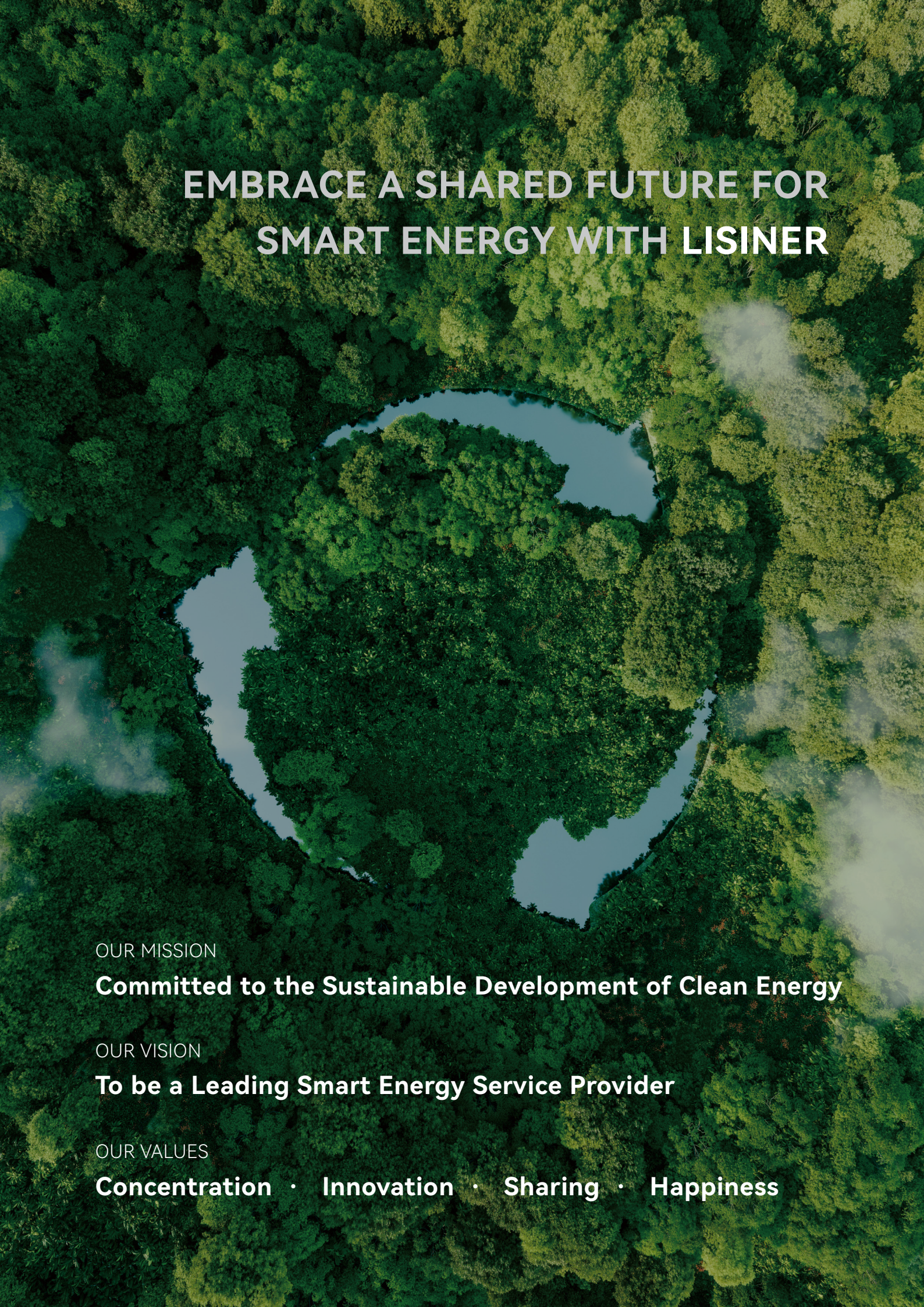

Data Analysis & Intelligent
Reporting

An aerial photograph of a dense, vibrant green forest. A winding river flows through the center of the forest, its surface reflecting the surrounding greenery. Soft, white mist or fog drifts through the trees, particularly on the right side, adding a sense of depth and atmosphere to the scene. The overall color palette is dominated by various shades of green, from deep forest greens to bright, sunlit highlights.

EMBRACE A SHARED FUTURE FOR SMART ENERGY WITH LISINER

OUR MISSION

Committed to the Sustainable Development of Clean Energy

OUR VISION

To be a Leading Smart Energy Service Provider

OUR VALUES

Concentration · Innovation · Sharing · Happiness

 www.lisiner.com

 info@yoening.com

 HANGZHOU CHANGSHA JIANGXI · CHINA